

AK

Cast iron sheaves
Light Duty -
Finished bore

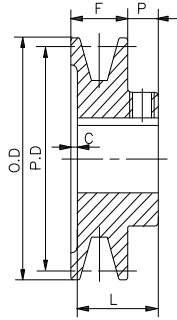

TYPE 1

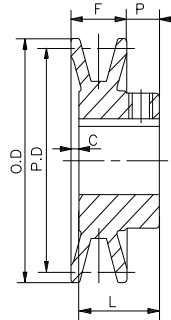

TYPE 2

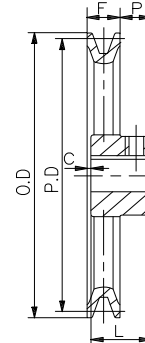

TYPE 3

Single Groove Sheaves for "4L" or "A" belts

"3L" Belts may be used with These Sheaves as Indicated in Table Below

Part No.	Diameter (Inches)			Type	Dimensions (Inches)				Stock bores marked ●										wt Lbs		
	OD	PD "A"	PD "3L"		F	L	P	C	1/2	5/8	3/4	7/8	15/16	1	1 1/8	1 3/16	1 1/4	1 3/8		1 7/16	
AK17	1.75	1.50	1.16	1	21/32	15/16	7/16	5/32	●	●											0.2
AK20	2.00	1.80	1.46	1	21/32	15/16	7/16	5/32	●	●	●										0.3
AK21	2.10	1.90	1.56	1	21/32	15/16	7/16	5/32	●	●	●										0.4
AK22	2.20	2.00	1.66	1	21/32	15/16	7/16	5/32	●	●	●										0.5
AK23	2.30	2.10	1.76	1	21/32	15/16	7/16	5/32	●	●	●										0.5
AK25	2.50	2.30	1.96	2	21/32	15/16	7/16	5/32	●	●	●										0.6
AK26	2.60	2.40	2.06	2	21/32	15/16	7/16	5/32	●	●	●										0.6
AK27	2.70	2.50	2.16	2	21/32	15/16	7/16	5/32	●	●	●										0.6
AK28	2.80	2.60	2.26	2	21/32	15/16	7/16	5/32	●	●	●										0.7
AK30	3.05	2.80	2.46	2	21/32	15/16	7/16	5/32	●	●	●	●									0.7
AK32	3.25	3.00	2.66	2	21/32	15/16	7/16	5/32	●	●	●	●									0.8
AK34	3.45	3.20	2.86	2	21/32	15/16	7/16	5/32	●	●	●	●									0.9
AK39	3.75	3.50	3.16	2	3/4	1 5/32	15/32	1/16	●	●	●	●	●	●							1.4
AK41	3.95	3.70	3.36	2	3/4	1 5/32	15/32	1/16	●	●	●	●	●	●							1.5
AK44	4.25	4.00	3.66	3	3/4	1 5/32	15/32	1/16	●	●	●	●	●	●	●						1.5
AK46	4.45	4.20	3.86	3	3/4	1 5/32	15/32	1/16	●	●	●	●	●	●	●						1.6
AK49	4.75	4.50	4.16	3	3/4	1 5/32	15/32	1/16	●	●	●	●	●	●	●						1.7
AK51	4.95	4.70	4.36	3	3/4	1 5/32	15/32	1/16	●	●	●	●	●	●	●						1.7
AK54	5.25	5.00	4.66	3	3/4	1 5/32	15/32	1/16	●	●	●	●	●	●	●	●					1.8
AK56	5.45	5.20	4.86	3	3/4	1 5/32	15/32	1/16	●	●	●	●	●	●	●	●					1.9
AK59	5.75	5.50	5.16	3	3/4	1 5/32	15/32	1/16	●	●	●	●	●	●	●	●					2.0
AK61	5.95	5.70	5.36	3	3/4	1 5/32	15/32	1/16	●	●	●	●	●	●	●	●					2.1
AK64	6.25	6.00	5.66	3	3/4	1 5/32	15/32	1/16	●	●	●	●	●	●	●	●					2.2
AK66	6.45	6.20	5.86	3	3/4	1 5/32	15/32	1/16		●	●			●	●						2.3
AK69	6.75	6.50	6.16	3	3/4	1 15/32	23/32	—			●			●	●						3.5
AK71	6.95	6.70	6.36	3	3/4	1 15/32	23/32	—			●	●		●	●					●	3.8
AK74	7.25	7.00	6.66	3	3/4	1 15/32	23/32	—	●	●	●			●	●	●	●			●	3.9
AK79	7.75	7.50	7.16	3	3/4	1 15/32	23/32	—			●			●	●					●	4.0
AK84	8.25	8.00	7.66	3	3/4	1 15/32	23/32	—	●	●	●			●	●	●				●	4.2
AK89	8.75	8.50	8.16	3	3/4	1 15/32	23/32	—			●			●	●					●	4.3
AK94	9.25	9.00	8.66	3	3/4	1 15/32	23/32	—	●	●	●			●	●	●				●	4.5
AK99	9.75	9.50	9.16	3	3/4	1 15/32	23/32	—			●			●	●					●	5.3
AK104	10.25	10.00	9.66	3	3/4	1 15/32	23/32	—			●	●		●	●	●	●			●	5.7
AK109	10.75	10.50	10.16	3	3/4	1 15/32	23/32	—			●			●	●					●	5.8
AK114	11.25	11.00	10.66	3	3/4	1 15/32	23/32	—			●			●	●					●	5.9
AK124	12.25	12.00	11.66	3	3/4	1 15/32	23/32	—			●	●		●	●	●				●	6.5
AK134	13.25	13.00	12.66	3	3/4	1 15/32	23/32	—			●			●	●					●	7.5
AK144	14.25	14.00	13.66	3	3/4	1 15/32	23/32	—			●			●	●					●	8.5
AK154	15.25	15.00	14.66	3	3/4	1 15/32	23/32	—			●			●	●					●	9.8
AK184	18.25	18.00	17.66	3	3/4	1 15/32	23/32	—			●			●	●					●	12.1

2AK

Cast iron sheaves
Light Duty -
Finished bore

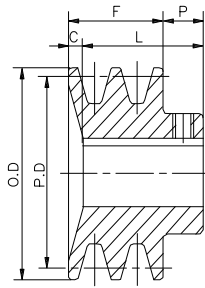

TYPE 1D

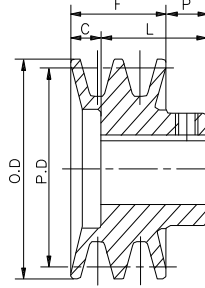

TYPE 2D

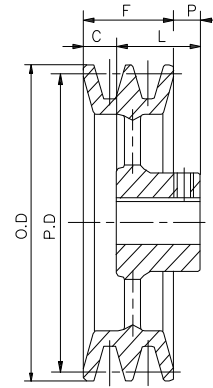

TYPE 3D

Double Groove Sheaves for "4L" or "A" belts

"3L" Belts may be used with These Sheaves as Indicated in Table Below

Part No.	Diameter (Inches)			Type	Dimensions (Inches)				Stock bores marked ●										wt Lbs		
	OD	PD "A"	PD "3L"		F	L	P	C	1/2	5/8	3/4	7/8	15/16	1	1 1/8	1 3/16	1 1/4	1 3/8		1 7/16	
2AK20	2.00	1.80	1.46	1D	1 3/8	1 21/32	15/32	3/16	●	●	●										0.8
2AK21	2.15	1.90	1.56	1D	1 3/8	1 21/32	15/32	3/16	●	●	●										0.9
2AK22	2.25	2.00	1.66	1D	1 3/8	1 21/32	15/32	3/16	●	●	●	●									1.0
2AK23	2.35	2.10	1.76	1D	1 3/8	1 21/32	15/32	3/16		●	●	●		●							1.1
2AK25	2.55	2.30	1.96	1D	1 3/8	1 21/32	15/32	3/16		●	●	●		●							1.3
2AK26	2.65	2.40	2.06	1D	1 3/8	1 21/32	15/32	3/16		●	●	●		●							1.4
2AK27	2.75	2.50	2.16	1D	1 3/8	1 21/32	15/32	3/16		●	●	●		●							1.5
2AK28	2.85	2.60	2.26	1D	1 3/8	1 21/32	15/32	3/16		●	●	●		●							1.8
2AK30	3.05	2.80	2.46	1D	1 3/8	1 21/32	15/32	3/16	●	●	●	●		●	●						1.9
2AK32	3.25	3.00	2.66	1D	1 3/8	1 21/32	15/32	3/16		●	●	●		●	●						2.1
2AK34	3.45	3.20	2.86	1D	1 3/8	1 21/32	15/32	3/16		●	●	●		●	●						2.3
2AK39	3.75	3.50	3.16	2D	1 3/8	1 11/32	15/32	1/2		●	●	●		●	●						2.6
2AK41	3.95	3.70	3.36	2D	1 3/8	1 11/32	15/32	1/2		●	●	●		●	●						2.9
2AK44	4.25	4.00	3.66	2D	1 3/8	1 11/32	15/32	1/2		●	●	●		●	●						3.0
2AK46	4.45	4.20	3.86	2D	1 3/8	1 11/32	15/32	1/2				●		●	●						3.1
2AK49	4.75	4.50	4.16	2D	1 3/8	1 11/32	15/32	1/2			●	●		●	●			●			3.6
2AK51	4.95	4.70	4.36	2D	1 3/8	1 11/32	15/32	1/2			●	●		●	●			●			3.8
2AK54	5.25	5.00	4.66	3D	1 3/8	1 11/32	15/32	1/2		●	●	●		●	●			●			3.3
2AK56	5.45	5.20	4.86	3D	1 3/8	1 11/32	15/32	1/2		●	●			●	●			●			3.4
2AK59	5.75	5.50	5.16	3D	1 3/8	1 11/32	15/32	1/2						●	●			●			3.5
2AK61	5.95	5.70	5.36	3D	1 3/8	1 11/32	15/32	1/8			●	●		●	●			●			3.6
2AK64	6.25	6.00	5.66	3D	1 3/8	1 19/32	11/32	1/8			●			●	●	●		●	●		4.8
2AK74	7.25	7.00	6.66	3D	1 3/8	1 19/32	11/32	1/8			●			●	●	●		●	●		5.6
2AK84	8.25	8.00	7.66	3D	1 3/8	1 19/32	11/32	1/8			●		●	●	●			●	●		6.4
2AK94	9.25	9.00	8.66	3D	1 3/8	1 19/32	11/32	1/8			●			●	●	●		●	●		7.3
2AK104	10.25	10.00	9.66	3D	1 3/8	1 19/32	11/32	1/8			●		●	●					●		8.1
2AK114	11.25	11.00	10.66	3D	1 3/8	1 19/32	11/32	1/8			●			●		●		●	●		9.0
2AK124	12.25	12.00	11.66	3D	1 3/8	1 19/32	11/32	1/8			●			●	●				●		9.8
2AK134	13.25	13.00	12.66	3D	1 3/8	1 19/32	11/32	1/8						●		●			●		12.3
2AK144	14.25	14.00	13.66	3D	1 3/8	1 19/32	11/32	1/8						●					●		13.9
2AK154	15.25	15.00	14.66	3D	1 3/8	1 19/32	11/32	1/8							●				●		14.3
2AK184	18.25	18.00	17.66	3D	1 3/8	1 19/32	11/32	1/8							●				●		17.4

BK

Cast iron sheaves
Light Duty -
Finished bore

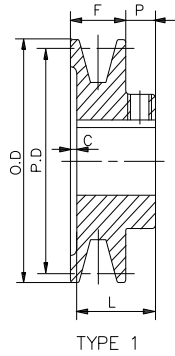

TYPE 1

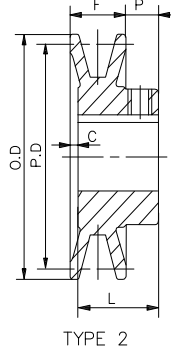

TYPE 2

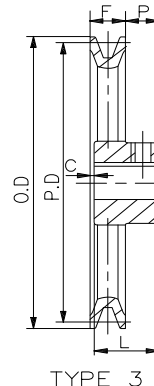

TYPE 3

Single Groove Sheaves for "4L" or "A" belts and "5L" or "B" belts

Part No.	Diameter (Inches)			Type	Dimensions (Inches)				Stock bores marked ●										wt Lbs		
	OD	PD "A"	PD "B"		F	L	P	C	1/2	5/8	3/4	7/8	15/16	1	1 1/8	1 3/16	1 1/4	1 3/8		1 7/16	
BK24	2.40	1.80	2.20	1	13/16	1 1/16	13/32	5/32	●	●	●										0.4
BK25	2.50	1.90	2.30	1	13/16	1 1/16	13/32	5/32	●	●	●	●									0.5
BK26	2.60	2.00	2.40	1	13/16	1 1/16	13/23	5/32	●	●	●	●									0.6
BK27	2.70	2.10	2.50	2	13/16	1 1/16	13/23	5/32	●	●	●	●									0.7
BK28	2.95	2.20	2.60	2	13/16	1 1/16	13/23	5/32	●	●	●	●									0.8
BK30	3.15	2.40	2.80	2	13/16	1 1/16	13/32	5/32	●	●	●	●									0.9
BK32	3.35	2.60	3.00	2	13/16	1 1/16	13/32	5/32	●	●	●	●									1.0
BK34	3.55	2.80	3.20	2	7/8	1 5/32	13/23	1/8	●	●	●	●	●	●							1.3
BK36	3.75	3.00	3.40	2	7/8	1 5/32	13/23	1/8	●	●	●	●		●	●						1.5
BK40	3.95	3.20	3.60	2	7/8	1 5/32	13/23	1/8	●	●	●	●		●	●						1.6
BK45	4.25	3.50	3.90	2	7/8	1 5/32	13/32	1/8	●	●	●	●		●	●						1.8
BK47	4.45	3.70	4.10	2	7/8	1 5/32	13/32	1/8	●	●	●	●		●	●						1.9
BK50	4.75	4.00	4.40	3	7/8	1 5/32	13/23	1/8	●	●	●	●	●	●	●						2.0
BK52	4.95	4.20	4.60	3	7/8	1 5/32	13/23	1/8	●	●	●	●		●	●						2.1
BK55	5.25	4.50	4.90	3	7/8	1 5/32	13/23	1/8	●	●	●	●		●	●						2.2
BK57	5.45	4.70	5.10	3	7/8	1 5/32	13/32	1/8		●	●	●	●	●	●						2.3
BK60	5.75	5.00	5.40	3	7/8	1 5/32	13/32	1/8	●	●	●	●	●	●	●	●					2.4
BK62	5.95	5.20	5.60	3	7/8	1 5/32	13/23	1/8	●	●	●	●	●	●	●						2.5
BK65	6.25	5.50	5.90	3	7/8	1 5/32	13/23	1/8		●	●	●	●	●	●	●					2.7
BK67	6.45	5.70	6.10	3	7/8	1 5/32	13/23	1/8		●	●	●	●	●	●	●					2.8
BK70	6.75	6.00	6.40	3	7/8	1 15/32	21/23	1/16		●	●	●	●	●	●	●				●	3.3
BK72	6.95	6.20	6.60	3	7/8	1 15/32	21/23	1/16			●	●	●	●	●	●			●		3.9
BK75	7.25	6.50	6.90	3	7/8	1 15/32	21/23	1/16			●	●	●	●	●	●			●		4.0
BK77	7.45	6.70	7.10	3	7/8	1 15/32	21/23	1/16			●	●	●	●	●	●			●		4.1
BK80	7.75	7.00	7.40	3	7/8	1 15/32	21/23	1/16		●	●	●	●	●	●	●	●	●	●		4.4
BK85	8.25	7.50	7.90	3	7/8	1 15/32	21/23	1/16			●	●	●	●	●	●			●	●	5.0
BK90	8.75	8.00	8.40	3	7/8	1 15/32	21/23	1/16			●	●	●	●	●	●	●	●	●		5.2
BK95	9.25	8.50	8.90	3	7/8	1 15/32	21/23	1/16			●	●	●	●	●	●	●	●	●		5.4
BK100	9.75	9.00	9.40	3	7/8	1 15/32	21/23	1/16			●	●	●	●	●	●	●	●	●		5.6
BK105	10.25	9.50	9.90	3	7/8	1 15/32	21/23	1/16				●	●	●	●	●	●	●	●		5.8
BK110	10.75	10.00	10.40	3	7/8	1 15/32	21/23	1/16			●	●	●	●	●	●	●	●	●		6.4
BK115	11.25	10.50	10.90	3	7/8	1 15/32	21/23	1/16				●	●	●	●	●	●	●	●		6.9
BK120	11.75	11.00	11.40	3	7/8	1 15/32	21/23	1/16			●	●	●	●	●	●	●	●	●		7.4
BK130	12.75	12.00	12.40	3	7/8	1 15/32	21/23	1/16				●	●	●	●	●	●	●	●		8.4
BK140	13.75	13.00	13.40	3	7/8	1 15/32	21/23	1/16			●	●	●	●	●	●	●	●	●		9.4
BK160	15.75	15.00	15.40	3	7/8	1 15/32	21/23	1/16				●	●	●	●	●	●	●	●		12.4
BK190	18.75	18.00	18.40	3	7/8	1 15/32	21/23	1/16					●	●	●	●	●	●	●		13.4

2BK

Cast iron sheaves
Light Duty -
Finished bore

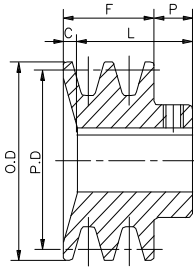

TYPE 1D

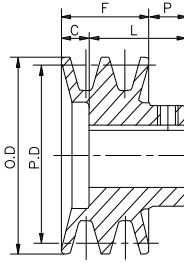

TYPE 2D

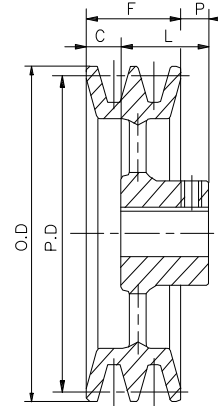

TYPE 3D

Double Groove Sheaves for "4L" or "A" belts and "5L" or "B" belts

Part No.	Diameter (Inches)			Type	Dimensions (Inches)				Stock bores marked ●											wt Lbs	
	OD	PD "A"	PD "B"		F	L	P	C	1/2	5/8	3/4	7/8	15/16	1	1 1/8	1 3/16	1 1/4	1 3/8	1 7/16		
2BK25	2.50	1.90	2.30	1D	1 3/4	1 31/32	15/32	1/4	●	●	●	●									1.3
2BK27	2.70	2.10	2.50	1D	1 3/4	1 31/32	15/32	1/4	●	●	●	●	●	●							1.6
2BK28	2.95	2.20	2.60	1D	1 3/4	1 31/32	15/32	1/4	●	●	●	●	●	●	●						1.9
2BK30	3.15	2.40	2.80	1D	1 3/4	1 31/32	15/32	1/4	●	●	●	●	●	●	●						2.3
2BK32	3.35	2.60	3.00	1D	1 3/4	1 31/32	15/32	1/4		●	●	●	●	●	●						2.6
2BK34	3.55	2.80	3.20	1D	1 3/4	1 31/32	15/32	1/4		●	●	●	●	●	●						2.8
2BK36	3.75	3.00	3.40	1D	1 3/4	1 31/32	15/32	1/4			●	●	●	●	●			●			3.3
2BK40	3.95	3.20	3.60	2D	1 3/4	1 15/32	15/32	3/4		●	●	●	●	●	●						3.4
2BK45	4.25	3.50	3.90	2D	1 3/4	1 15/32	15/32	3/4					●	●	●			●			3.6
2BK47	4.45	3.70	4.10	2D	1 3/4	1 15/32	15/32	3/4				●	●	●	●						3.7
2BK50	4.75	4.00	4.40	2D	1 3/4	1 15/32	15/32	3/4			●		●	●	●			●			4.1
2BK52	4.95	4.20	4.60	2D	1 3/4	1 15/32	15/32	3/4				●	●	●	●			●			4.5
2BK55	5.25	4.50	4.90	2D	1 3/4	1 15/32	15/32	3/4					●	●	●			●			4.8
2BK57	5.45	4.70	5.10	2D	1 3/4	1 15/32	15/32	3/4					●	●	●			●			5.1
2BK60	5.75	5.00	5.40	3D	1 3/4	1 15/32	15/32	3/4			●	●	●	●	●			●			4.9
2BK62	5.95	5.20	5.60	3D	1 3/4	1 15/32	15/32	3/4					●	●	●			●			4.8
2BK65	6.25	5.50	5.90	3D	1 3/4	1 15/32	15/32	3/4					●	●	●			●			5.0
2BK67	6.45	5.70	6.10	3D	1 3/4	1 15/32	15/32	3/4					●	●	●			●			5.5
2BK70	6.75	6.00	6.40	3D	1 3/4	1 19/32	11/32	1/2			●		●	●	●	●		●	●		6.0
2BK80	7.75	7.00	7.40	3D	1 3/4	1 19/32	11/32	1/2			●		●	●	●	●		●	●		7.2
2BK90	8.75	8.00	8.40	3D	1 3/4	1 19/32	11/32	1/2			●		●	●	●	●		●	●		8.4
2BK100	9.75	9.00	9.40	3D	1 3/4	1 19/32	11/32	1/2			●		●	●	●	●		●	●		9.4
2BK110	10.75	10.00	10.40	3D	1 3/4	1 19/32	11/32	1/2					●	●	●	●		●	●		10.4
2BK120	11.75	11.00	11.40	3D	1 3/4	1 19/32	11/32	1/2					●	●	●	●		●	●		11.8
2BK130	12.75	12.00	12.40	3D	1 3/4	1 19/32	11/32	1/2					●	●	●	●		●	●		14.9
2BK140	13.75	13.00	13.40	3D	1 3/4	1 19/32	11/32	1/2					●	●	●	●		●	●		16.3
2BK160	15.75	15.00	15.40	3D	1 3/4	1 19/32	11/32	1/2					●	●	●	●		●	●		18.0
2BK190	18.75	18.00	18.40	3D	1 3/4	1 19/32	11/32	1/2					●	●	●	●		●	●		23.4

3BK

Cast iron sheaves
Light Duty -
Finished bore

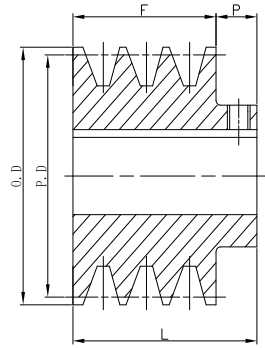

TYPE 3T

Three Groove Sheaves for "4L" or "A" belts and "5L" or "B" belts

Part No.	Diameter (Inches)			Type	Dimensions (Inches)			Stock bores marked ●										wt Lbs		
	OD	PD "A"	PD "B"		F	L	P			5/8		7/8			1				1 1/8	
3BK25	2.50	1.90	2.30	3T	2 1/2	3	1/2			●		●								1.7
3BK27	2.70	2.10	2.50	3T	2 1/2	3	1/2			●		●		●						2.1
3BK28	2.95	2.20	2.60	3T	2 1/2	3	1/2			●		●		●				●		2.5
3BK30	3.15	2.40	2.80	3T	2 1/2	3	1/2					●		●				●		3.0
3BK32	3.35	2.60	3.00	3T	2 1/2	3	1/2					●		●				●		3.4
3BK34	3.55	2.80	3.20	3T	2 1/2	3	1/2					●		●				●		3.8
3BK36	3.75	3.00	3.40	3T	2 1/2	3	1/2					●		●				●		4.3
3BK40	3.95	3.20	3.60	3T	2 1/2	3	1/2					●		●				●		4.7

Standard Keyway Dimensions - Inches

Bore range	Keyway
1/2	None
5/8 - 7/8	3/16 x 3/32
15/16 - 1 1/4	1/4 x 1/8
1 5/16 - 1 3/8	5/16 x 5/32
1 7/16	3/8 x 3/16

AK-H

Cast iron sheaves
Light Duty -
"H" bushing

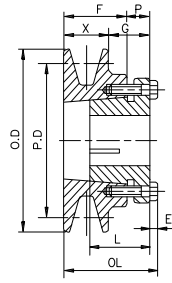

TYPE 1

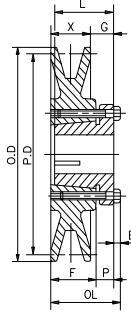

TYPE 2

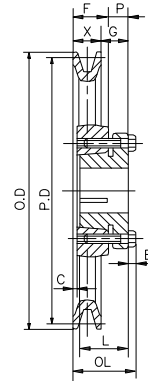

TYPE 3

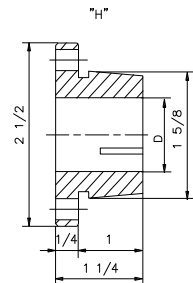

STL-H

Single Groove Sheaves for "4L" or "A" belts

"3L" Belts may be used with These Sheaves as Indicated in Table Below

Part No.	Diameter (Inches)			Type	Dimensions (Inches)								wt less Bush
	OD	PD "A"	PD "3L"		OL	F	L	P	C	X	G	E	
AK30H	3.05	2.80	2.46	1	1 13/16	3/4	1 1/4	7/8	—	1 3/16	7/16	3/16	1.1
AK32H	3.25	3.00	2.66	1	1 13/16	3/4	1 1/4	7/8	—	1 3/16	7/16	3/16	1.2
AK34H	3.45	3.20	2.86	2	1 1/2	3/4	1 1/4	9/16	—	7/8	7/16	3/16	1.2
AK39H	3.75	3.50	3.16	2	1 1/2	3/4	1 1/4	9/16	—	7/8	7/16	3/16	1.4
AK41H	3.95	3.70	3.36	2	1 1/2	3/4	1 1/4	9/16	—	7/8	7/16	3/16	1.6
AK44H	4.25	4.00	3.66	2	1 1/2	3/4	1 1/4	9/16	—	7/8	7/16	3/16	1.9
AK46H	4.45	4.20	3.86	2	1 1/2	3/4	1 1/4	9/16	—	7/8	7/16	3/16	1.9
AK49H	4.75	4.50	4.16	2	1 1/2	3/4	1 1/4	9/16	—	7/8	7/16	3/16	2.1
AK51H	4.95	4.70	4.36	2	1 1/2	3/4	1 1/4	9/16	—	7/8	7/16	3/16	2.3
AK54H	5.25	5.00	4.66	2	1 1/2	3/4	1 1/4	9/16	—	7/8	7/16	3/16	2.0
AK56H	5.45	5.20	4.86	2	1 1/2	3/4	1 1/4	9/16	—	7/8	7/16	3/16	2.3
AK59H	5.75	5.50	5.16	2	1 1/2	3/4	1 1/4	9/16	—	7/8	7/16	3/16	2.4
AK61H	5.95	5.70	5.36	3	1 1/2	3/4	1 1/4	9/16	—	7/8	7/16	3/16	2.5
AK64H	6.25	6.00	5.66	3	1 1/2	3/4	1 1/4	9/16	—	7/8	7/16	3/16	2.7
AK66H	6.45	6.20	5.86	3	1 1/2	3/4	1 1/4	9/16	—	7/8	7/16	3/16	2.8
AK69H	6.75	6.50	6.16	3	1 1/2	3/4	1 1/4	9/16	—	7/8	7/16	3/16	3.2
AK71H	6.95	6.70	6.36	3	1 1/2	3/4	1 1/4	9/16	—	7/8	7/16	3/16	3.3
AK74H	7.25	7.00	6.66	3	1 1/2	3/4	1 1/4	9/16	—	7/8	7/16	3/16	3.3
AK79H	7.75	7.50	7.16	3	1 1/2	3/4	1 1/4	9/16	—	7/8	7/16	3/16	3.5
AK84H	8.25	8.00	7.66	3	1 1/2	3/4	1 1/4	9/16	—	7/8	7/16	3/16	3.6
AK89H	8.75	8.50	8.16	3	1 1/2	3/4	1 1/4	9/16	—	7/8	7/16	3/16	4.0
AK94H	9.25	9.00	8.66	3	1 1/2	3/4	1 1/4	9/16	—	7/8	7/16	3/16	4.4
AK99H	9.75	9.50	9.16	3	1 1/2	3/4	1 1/4	9/16	—	7/8	7/16	3/16	4.7
AK104H	10.25	10.00	9.66	3	1 1/2	3/4	1 1/4	9/16	—	7/8	7/16	3/16	4.8
AK109H	10.75	10.50	10.16	3	1 1/2	3/4	1 1/4	9/16	—	7/8	7/16	3/16	5.1
AK114H	11.25	11.00	10.66	3	1 1/2	3/4	1 1/4	9/16	—	7/8	7/16	3/16	5.5
AK124H	12.25	12.00	11.66	3	1 1/2	3/4	1 1/4	9/16	—	7/8	7/16	3/16	6.1
AK134H	13.25	13.00	12.66	3	1 1/2	3/4	1 1/4	9/16	—	7/8	7/16	3/16	7.4
AK144H	14.25	14.00	13.66	3	1 1/2	3/4	1 1/4	9/16	—	7/8	7/16	3/16	7.8
AK154H	15.25	15.00	14.66	3	1 1/2	3/4	1 1/4	9/16	—	7/8	7/16	3/16	8.8
AK184H	18.25	18.00	17.66	3	1 1/2	3/4	1 1/4	9/16	—	7/8	7/16	3/16	11.3

2AK-H

Cast iron sheaves
Light Duty -
" H " bushing

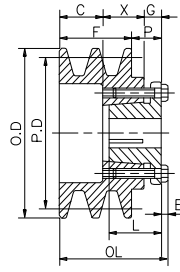

TYPE 1D

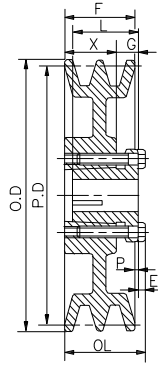

TYPE 2D

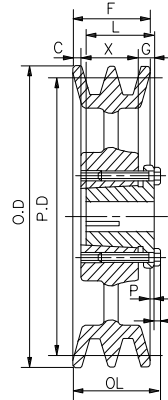

TYPE 3D

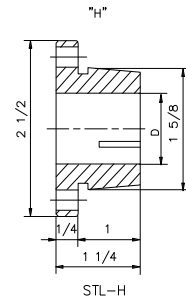

STL-H

Double Groove Sheaves for "4L" or "A" belts

"3L" Belts may be used with These Sheaves as Indicated in Table Below

Part No.	Diameter (Inches)			Type	Dimensions (Inches)								wt less Bush
	OD	PD "A"	PD "3L"		OL	F	L	P	C	X	G	E	
2AK30H	3.05	2.80	2.46	1D	2 7/16	1 3/8	1 1/4	7/8	15/16	7/8	7/16	3/16	1.4
2AK32H	3.25	3.00	2.66	1D	2 7/16	1 3/8	1 1/4	7/8	15/16	7/8	7/16	3/16	1.7
2AK34H	3.45	3.20	2.86	1D	2	1 3/8	1 1/4	7/16	1/2	7/8	7/16	3/16	1.8
2AK39H	3.75	3.50	3.16	1D	2	1 3/8	1 1/4	7/16	1/2	7/8	7/16	3/16	1.8
2AK41H	3.95	3.70	3.36	2D	1 1/2	1 3/8	1 1/4	1/16	—	7/8	7/16	3/16	1.9
2AK44H	4.25	4.00	3.66	2D	1 1/2	1 3/8	1 1/4	1/16	—	7/8	7/16	3/16	2.4
2AK46H	4.45	4.20	3.86	2D	1 1/2	1 3/8	1 1/4	1/16	—	7/8	7/16	3/16	2.5
2AK49H	4.75	4.50	4.16	2D	1 1/2	1 3/8	1 1/4	1/16	—	7/8	7/16	3/16	3.1
2AK51H	4.95	4.70	4.36	2D	1 1/2	1 3/8	1 1/4	1/16	—	7/8	7/16	3/16	3.2
2AK54H	5.25	5.00	4.66	2D	1 1/2	1 3/8	1 1/4	1/16	—	7/8	7/16	3/16	3.4
2AK56H	5.45	5.20	4.86	2D	1 1/2	1 3/8	1 1/4	1/16	—	7/8	7/16	3/16	3.6
2AK59H	5.75	5.50	5.16	3D	1 1/2	1 3/8	1 1/4	1/16	—	7/8	7/16	3/16	3.7
2AK61H	5.95	5.70	5.36	3D	1 1/2	1 3/8	1 1/4	1/16	—	7/8	7/16	3/16	3.8
2AK64H	6.25	6.00	5.66	3D	1 1/2	1 3/8	1 1/4	1/16	—	7/8	7/16	3/16	3.9
2AK74H	7.25	7.00	6.66	3D	1 1/2	1 3/8	1 1/4	1/16	—	7/8	7/16	3/16	4.9
2AK84H	8.25	8.00	7.66	3D	1 1/2	1 3/8	1 1/4	1/16	—	7/8	7/16	3/16	5.8
2AK94H	9.25	9.00	8.66	3D	1 1/2	1 3/8	1 1/4	1/16	—	7/8	7/16	3/16	6.1
2AK104H	10.25	10.00	9.66	3D	1 1/2	1 3/8	1 1/4	1/16	—	7/8	7/16	3/16	7.7
2AK114H	11.25	11.00	10.66	3D	1 1/2	1 3/8	1 1/4	1/16	—	7/8	7/16	3/16	8.5
2AK124H	12.25	12.00	11.66	3D	1 1/2	1 3/8	1 1/4	1/16	—	7/8	7/16	3/16	9.5
2AK134H	13.25	13.00	12.66	3D	1 1/2	1 3/8	1 1/4	1/16	—	7/8	7/16	3/16	11.4
2AK144H	14.25	14.00	13.66	3D	1 1/2	1 3/8	1 1/4	1/16	—	7/8	7/16	3/16	11.9
2AK154H	15.25	15.00	14.66	3D	1 1/2	1 3/8	1 1/4	1/16	—	7/8	7/16	3/16	13.3
2AK184H	18.25	18.00	17.66	3D	1 1/2	1 3/8	1 1/4	1/16	—	7/8	7/16	3/16	16.8

BK-H

Cast iron sheaves
Light Duty -
" H " bushing

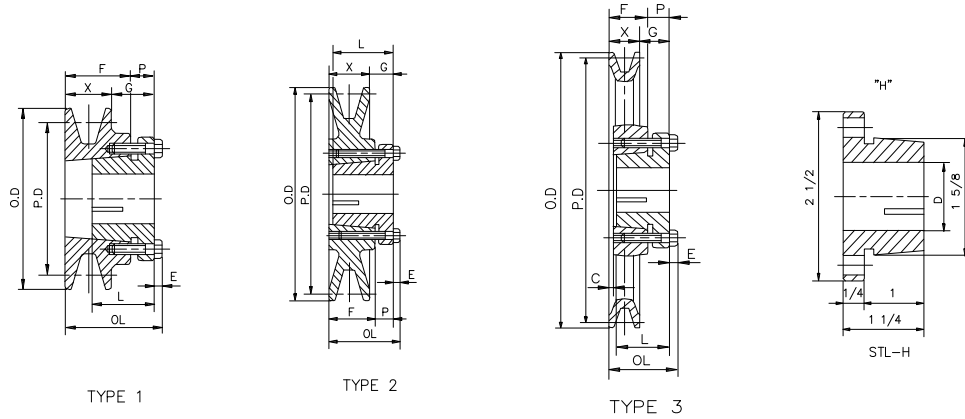

Single Groove Sheaves for "4L" or "A" belts and "5L" or "B" belts

Part No.	Diameter (Inches)			Type	Dimensions (Inches)								wt less Bush
	OD	PD "A"	PD "3L"		OL	F	L	P	C	X	G	E	
BK30H	3.15	2.40	2.80	1	1 15/16	7/8	1 1/4	7/8	—	1 5/16	7/16	3/16	1.2
BK32H	3.35	2.60	3.00	1	1 15/16	7/8	1 1/4	7/8	—	1 5/16	7/16	3/16	1.4
BK34H	3.55	2.80	3.20	1	1 15/16	7/8	1 1/4	7/8	—	1 5/16	7/16	3/16	1.6
BK36H	3.75	3.00	3.40	2	1 1/2	7/8	1 1/4	7/16	—	7/8	7/16	3/16	1.2
BK40H	3.95	3.20	3.60	2	1 1/2	7/8	1 1/4	7/16	—	7/8	7/16	3/16	1.4
BK45H	4.25	3.50	3.90	2	1 1/2	7/8	1 1/4	7/16	—	7/8	7/16	3/16	1.8
BK47H	4.45	3.70	4.10	2	1 1/2	7/8	1 1/4	7/16	—	7/8	7/16	3/16	2.2
BK50H	4.75	4.00	4.40	2	1 1/2	7/8	1 1/4	7/16	—	7/8	7/16	3/16	2.0
BK52H	4.95	4.20	4.60	2	1 1/2	7/8	1 1/4	7/16	—	7/8	7/16	3/16	2.1
BK55H	5.25	4.50	4.90	2	1 1/2	7/8	1 1/4	7/16	—	7/8	7/16	3/16	2.7
BK57H	5.45	4.70	5.10	2	1 1/2	7/8	1 1/4	7/16	—	7/8	7/16	3/16	2.7
BK60H	5.75	5.00	5.40	2	1 1/2	7/8	1 1/4	7/16	—	7/8	7/16	3/16	2.5
BK62H	5.95	5.20	5.60	2	1 1/2	7/8	1 1/4	7/16	—	7/8	7/16	3/16	2.6
BK65H	6.25	5.50	5.90	2	1 1/2	7/8	1 1/4	7/16	—	7/8	7/16	3/16	2.8
BK67H	6.45	5.70	6.10	2	1 1/2	7/8	1 1/4	7/16	—	7/8	7/16	3/16	2.9
BK70H	6.75	6.00	6.40	3	1 9/16	7/8	1 1/4	1/2	1/16	7/8	7/16	3/16	2.8
BK72H	6.95	6.20	6.60	3	1 9/16	7/8	1 1/4	1/2	1/16	7/8	7/16	3/16	3.1
BK75H	7.25	6.50	6.90	3	1 9/16	7/8	1 1/4	1/2	1/16	7/8	7/16	3/16	3.3
BK77H	7.45	6.70	7.10	3	1 9/16	7/8	1 1/4	1/2	1/16	7/8	7/16	3/16	3.8
BK80H	7.75	7.00	7.40	3	1 9/16	7/8	1 1/4	1/2	1/16	7/8	7/16	3/16	3.4
BK85H	8.25	7.50	7.90	3	1 9/16	7/8	1 1/4	1/2	1/16	7/8	7/16	3/16	3.8
BK90H	8.75	8.00	8.40	3	1 9/16	7/8	1 1/4	1/2	1/16	7/8	7/16	3/16	4.3
BK95H	9.25	8.50	8.90	3	1 9/16	7/8	1 1/4	1/2	1/16	7/8	7/16	3/16	5.0
BK100H	9.75	9.00	9.40	3	1 9/16	7/8	1 1/4	1/2	1/16	7/8	7/16	3/16	5.2
BK105H	10.25	9.50	9.90	3	1 9/16	7/8	1 1/4	1/2	1/16	7/8	7/16	3/16	5.5
BK110H	10.75	10.00	10.40	3	1 9/16	7/8	1 1/4	1/2	1/16	7/8	7/16	3/16	6.0
BK115H	11.25	10.50	10.90	3	1 9/16	7/8	1 1/4	1/2	1/16	7/8	7/16	3/16	6.4
BK120H	11.75	11.00	11.40	3	1 9/16	7/8	1 1/4	1/2	1/16	7/8	7/16	3/16	6.9
BK130H	12.75	12.00	12.40	3	1 9/16	7/8	1 1/4	1/2	1/16	7/8	7/16	3/16	6.9
BK140H	13.75	13.00	13.40	3	1 9/16	7/8	1 1/4	1/2	1/16	7/8	7/16	3/16	8.5
BK150H	14.75	14.00	14.40	3	1 9/16	7/8	1 1/4	1/2	1/16	7/8	7/16	3/16	9.5
BK160H	15.75	15.00	15.40	3	1 9/16	7/8	1 1/4	1/2	1/16	7/8	7/16	3/16	9.8
BK190H	18.75	18.00	18.40	3	1 9/16	7/8	1 1/4	1/2	1/16	7/8	7/16	3/16	12.8

2BK-H

Cast iron sheaves
Light Duty -
"H" bushing

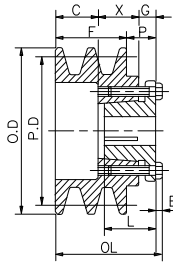

TYPE 1D

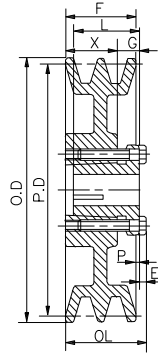

TYPE 2D

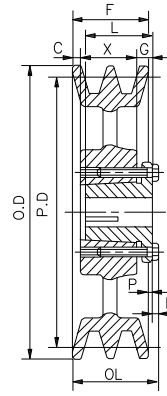

TYPE 3D

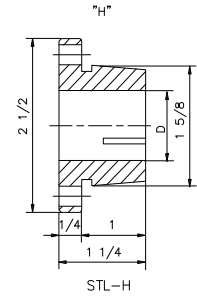

STL-H

Double Groove Sheaves for "4L" or "A" belts and "5L" or "B" belts

Part No.	Diameter (Inches)			Type	Dimensions (Inches)								wt less Bush
	OD	PD "A"	PD "3L"		OL	F	L	P	C	X	G	E	
2BK32H	3.35	2.60	3.00	1D	2 13/16	1 3/4	1 1/4	7/8	1 5/16	7/8	7/16	3/16	2.1
2BK34H	3.55	2.80	3.20	1D	2 13/16	1 3/4	1 1/4	7/8	1 5/16	7/8	7/16	3/16	2.4
2BK36H	3.75	3.00	3.40	1D	2 3/8	1 3/4	1 1/4	7/16	7/8	7/8	7/16	3/16	2.0
2BK40H	3.95	3.20	3.60	1D	2 3/8	1 3/4	1 1/4	7/16	7/8	7/8	7/16	3/16	2.4
2BK45H	4.25	3.50	3.90	1D	2 3/8	1 3/4	1 1/4	7/16	7/8	7/8	7/16	3/16	3.0
2BK47H	4.45	3.70	4.10	2D	1 3/4	1 3/4	1 1/4	7/16	—	7/8	7/16	3/16	2.8
2BK50H	4.75	4.00	4.40	2D	1 3/4	1 3/4	1 1/4	7/16	—	7/8	7/16	3/16	3.3
2BK52H	4.95	4.20	4.60	2D	1 3/4	1 3/4	1 1/4	7/16	—	7/8	7/16	3/16	3.6
2BK55H	5.25	4.50	4.90	2D	1 3/4	1 3/4	1 1/4	7/16	—	7/8	7/16	3/16	3.9
2BK57H	5.45	4.70	5.10	2D	1 3/4	1 3/4	1 1/4	7/16	—	7/8	7/16	3/16	4.3
2BK60H	5.75	5.00	5.40	2D	1 3/4	1 3/4	1 1/4	7/16	—	7/8	7/16	3/16	4.4
2BK62H	5.95	5.20	5.60	2D	1 3/4	1 3/4	1 1/4	7/16	—	7/8	7/16	3/16	4.5
2BK65H	6.25	5.50	5.90	3D	1 3/4	1 3/4	1 1/4	7/16	1/4	7/8	7/16	3/16	5.0
2BK67H	6.45	5.70	6.10	3D	1 3/4	1 3/4	1 1/4	7/16	1/4	7/8	7/16	3/16	5.1
2BK70H	6.75	6.00	6.40	3D	1 3/4	1 3/4	1 1/4	7/16	1/4	7/8	7/16	3/16	6.4
2BK80H	7.75	7.00	7.40	3D	1 3/4	1 3/4	1 1/4	7/16	1/4	7/8	7/16	3/16	7.6
2BK90H	8.75	8.00	8.40	3D	1 3/4	1 3/4	1 1/4	7/16	1/4	7/8	7/16	3/16	8.4
2BK100H	9.75	9.00	9.40	3D	1 3/4	1 3/4	1 1/4	7/16	1/4	7/8	7/16	3/16	9.3
2BK110H	10.75	10.00	10.40	3D	1 3/4	1 3/4	1 1/4	7/16	1/4	7/8	7/16	3/16	11.0
2BK120H	11.75	11.00	11.40	3D	1 3/4	1 3/4	1 1/4	7/16	1/4	7/8	7/16	3/16	13.1
2BK130H	12.75	12.00	12.40	3D	1 3/4	1 3/4	1 1/4	7/16	1/4	7/8	7/16	3/16	14.8
2BK140H	13.75	13.00	13.40	3D	1 3/4	1 3/4	1 1/4	7/16	1/4	7/8	7/16	3/16	16.2
2BK160H	15.75	15.00	15.40	3D	1 3/4	1 3/4	1 1/4	7/16	1/4	7/8	7/16	3/16	17.5
2BK190H	18.75	18.00	18.40	3D	1 3/4	1 3/4	1 1/4	7/16	1/4	7/8	7/16	3/16	21.5

3BK-H

Cast iron sheaves
Light Duty -
"H" bushing

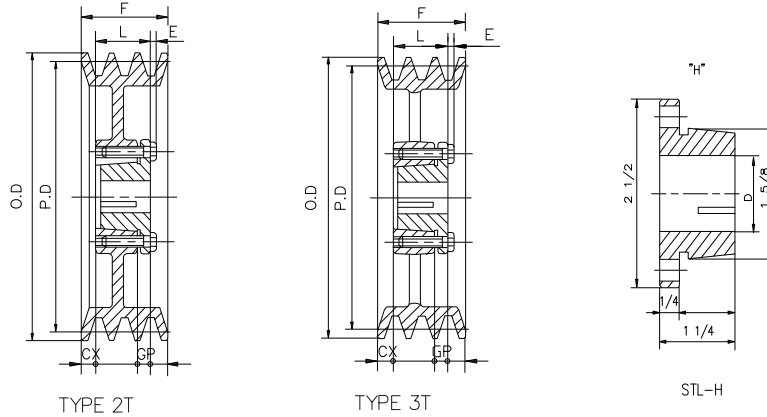

Three Groove Sheaves for "4L" or "A" belts and "5L" or "B" belts

Part No.	Diameter (Inches)			Type	Dimensions (Inches)								wt less Bush
	OD	PD "A"	PD "3L"		OL	F	L	P	C	X	G	E	
3BK45H	4.25	3.50	3.90	2T	2 5/8	2 1/2	1 1/4	1/2	11/16	7/8	7/16	3/16	3.9
3BK47H	4.45	3.70	4.10	2T	2 11/16	2 1/2	1 1/4	1/2	11/16	7/8	7/16	3/16	4.2
3BK50H	4.75	4.00	4.40	2T	3	2 1/2	1 1/4	1/2	11/16	7/8	7/16	3/16	4.4
3BK52H	4.95	4.20	4.60	2T	3 3/16	2 1/2	1 1/4	1/2	11/16	7/8	7/16	3/16	4.7
3BK55H	5.25	4.50	4.90	2T	3 1/2	2 1/2	1 1/4	1/2	11/16	7/8	7/16	3/16	5.1
3BK57H	5.45	4.70	5.10	2T	3 11/16	2 1/2	1 1/4	1/2	11/16	7/8	7/16	3/16	5.3
3BK60H	5.75	5.00	5.40	3T	4	2 1/2	1 1/4	1/2	11/16	7/8	7/16	3/16	5.6
3BK62H	5.95	5.20	5.60	3T	4 3/16	2 1/2	1 1/4	1/2	11/16	7/8	7/16	3/16	5.8
3BK65H	6.25	5.50	5.90	3T	4 1/2	2 1/2	1 1/4	29/32	9/32	7/8	7/16	3/16	5.8
3BK67H	6.45	5.70	6.10	3T	4 11/16	2 1/2	1 1/4	29/32	9/32	7/8	7/16	3/16	6.2
3BK70H	6.75	6.00	6.40	3T	5	2 1/2	1 1/4	29/32	9/32	7/8	7/16	3/16	6.6
3BK80H	7.75	7.00	7.40	3T	6	2 1/2	1 1/4	27/32	11/32	7/8	7/16	3/16	8.3
3BK90H	8.75	8.00	8.40	3T	7	2 1/2	1 1/4	27/32	11/32	7/8	7/16	3/16	9.8
3BK100H	9.75	9.00	9.40	3T	8	2 1/2	1 1/4	27/32	11/32	7/8	7/16	3/16	10.9
3BK110H	10.75	10.00	10.40	3T	9	2 1/2	1 1/4	27/32	11/32	7/8	7/16	3/16	12.1
3BK120H	11.75	11.00	11.40	3T	10	2 1/2	1 1/4	27/32	11/32	7/8	7/16	3/16	14.3
3BK130H	12.75	12.00	12.40	3T	11	2 1/2	1 1/4	25/32	13/32	7/8	7/16	3/16	16.2
3BK140H	13.75	13.00	13.40	3T	12	2 1/2	1 1/4	25/32	13/32	7/8	7/16	3/16	17.7
3BK160H	15.75	15.00	15.40	3T	14	2 1/2	1 1/4	25/32	13/32	7/8	7/16	3/16	21.0
3BK190H	18.75	18.00	18.40	3T	17	2 1/2	1 1/4	25/32	13/32	7/8	7/16	3/16	25.8