

# Straight Bevel Gears

Fekerman



Mod.	Z	De	Dp	H	F	d	D	V+H	L	Lm
2	16	34.8	32.0	20	9	25	10	28.8	17	9.3
	20	42.8	40.0	25	12	32	10	35.7	22	12
	22	46.8	44.0	25	12	36	10	37.7	22	17.7
	25	52.8	50.0	28	14	40	12	42.3	25	12.3
	30	62.8	60.0	30	16	50	12	47.8	27	12.8
2.5	16	43.5	40.0	25.5	10	32	12	37.3	22	13.3
	20	53.5	50.0	30.5	12	40	12	45.9	27	16
	22	58.5	55.0	30.5	12	45	12	48.3	27	15.9
	25	66	62.5	33.5	15	50	15	53.0	30	16
	30	78.5	75.0	35.5	18	55	15	59.1	32	16
3	16	52.2	48.0	30	12	40	15	44.2	26	16.2
	20	64.2	60.0	35	18	45	15	51.1	31	13.6
	22	70.2	66.0	35	18	50	15	54.0	31	13
	25	79.2	75.0	38	20	55	15	60.1	34	16
	30	94.4	90.0	40	22	60	20	68.1	36	19
3.5	16	60.9	56.0	35.5	16	45	15	50.8	31	17.2
	20	74.9	70.0	40.5	22	55	15	58.6	36	19
	22	81.9	77.0	40.5	22	60	15	62.0	36	18
	25	92.4	87.5	43.5	26	65	20	67.5	39	18
	30	109.9	105.0	45.5	30	70	20	75.4	41	17
4	16	69.6	64.0	38	18	50	15	55.6	33	16.6
	20	85.6	80.0	43	25	60	18	63.8	38	18
	22	93.6	88.0	43	25	65	18	67.7	38	18
	25	105.6	100.0	45	28	70	20	73.5	40	18
	30	125.6	120.0	48	32	80	25	83.7	43	16
4.5	16	78.3	72.0	43	20	55	18	63.0	37	18.5
	20	96.3	90.0	48	28	65	20	71.5	42	18
	22	105.3	99.0	48	28	70	20	75.8	42	18
	25	118.8	112.5	50	32	75	20	81.8	44	18
	30	141.3	135.0	53	35	90	25	93.8	47	17
5	16	87	80.0	45.5	22	60	20	67.8	39	17.8
	20	107.1	100.0	50.5	30	70	20	77.3	44	18.5
	22	117.1	110.0	50.5	30	80	20	82.2	44	18.5
	25	132.1	125.0	54.5	35	90	20	90.2	48	18.5
	30	157.1	150.0	56.5	38	110	30	102.4	50	18

**Type A**  
**Pressure angle 20°**  
**Ratio 1:1**

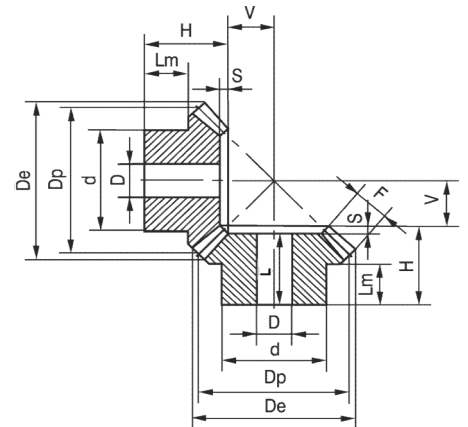

Mod.	Z	De	Dp	H	F	d	D	V+H	L	Lm
2	16	35.6	32	23	10	27	10	45.4	21	12.2
	32	65.8	64	25	10	40	12	35.2	22	10
2.5	16	44.4	40	27.5	12	34	12	56	25	14.4
	32	82.2	80	30	12	50	15	43	26.5	15
3	16	53.4	48	28	15	40	15	61.6	25	11.6
	32	98.7	96	35	15	60	15	50.4	30.5	15
3.5	16	62.3	56	33.5	18	48	15	72.3	30.5	14.4
	32	115.1	112	40	18	70	20	57.7	35	19
4	16	71.1	64	36	20	50	20	80.8	32	13.4
	32	131.6	128	45	20	80	20	65.5	39.5	23
4.5	16	80.1	72	39.5	22	60	20	90.4	35	15.4
	32	148	144	50	22	80	25	73.2	43.5	24
5	16	88.9	80	50	25	60	20	106.1	45	21.1
	32	164.5	160	55	25	85	25	80.6	48	27

**Type A**  
**Pressure angle 20°**  
**Ratio 1:2**

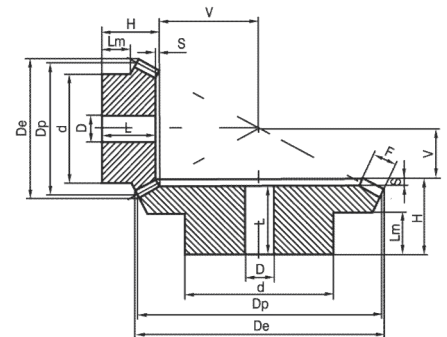

Accept custom made gears.

Mod.	Z	De	Dp	H	F	d	D	V+H	L	Lm
2	16	35.8	32	26.5	15	25	12	58.9	24	9.4
	48	97.3	96	26	15	30	15	35.9	22	13
2.5	16	44.7	40	28	18	33	14	70.4	26	9.2
	48	121.6	120	32	18	60	20	44.6	27	16
3	16	53.7	48	30	18	42	15	84.2	28	11.2
	48	145.9	144	38	18	65	20	54.1	32	19
3.5	16	62.6	56	36.5	22	48	15	98.8	34	13.4
	48	170.2	168	44	22	75	20	62.5	37	23
4	16	71.6	64	42	25	55	20	113.5	39	15.7
	48	194.5	192	50	25	85	22	71.2	42	27
4.5	16	80.6	72	53	28	60	20	133.4	50	23.4
	48	218.8	216	58	28	90	25	81.9	49	27
5	16	89.5	80	60	35	60	20	145.7	57	22.5
	48	243.1	240	65	35	100	28	90.5	55	35

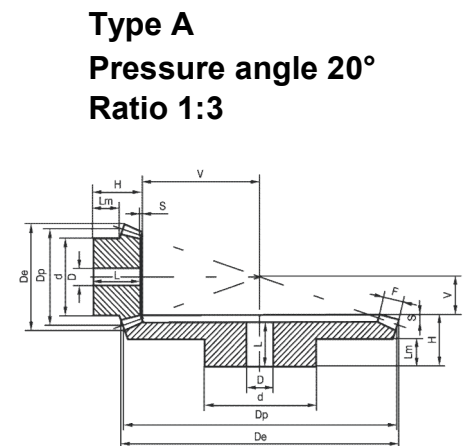

Mod.	Z	De	Dp	H	F	d	D	V+H	L	Lm
2	16	35.9	32	24	15	25	12	71.3	23	8.5
	64	129	128	28	15	70	20	38.9	24	14
2.5	16	44.9	40	30.5	18	34	15	92.6	29	11.7
	64	161.2	160	35	18	80	20	48.8	30	16
3	16	53.8	48	32	20	40	15	108	30	11.1
	64	193.5	192	42	20	90	20	58.8	36	22
3.5	16	62.8	56	40	25	45	15	127.1	38	14
	64	225.7	224	50	25	100	25	69.3	43	22
4	16	71.7	64	50	30	50	20	148.2	48	18.5
	64	257.9	256	60	30	110	28	81.8	52	30
4.5	16	80.7	72	55	32	60	20	167.1	53	21.6
	64	290.1	288	65	32	120	30	89.8	57	35
5	16	89.7	80	60	35	65	20	185.1	58	23.2
	64	322.4	320	70	35	120	30	97.7	61	42

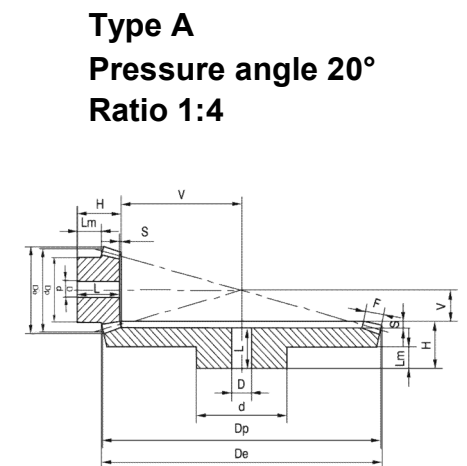

Material selection: Steel C45, 42CrMo, 20CrMnTi.

Surface treatment selection: Hardening teeth, Oil, Black oxide, Carburizing.

For large module gears, or not 45°gears, pls contact Fekerman directly.

Accept custom made gears.

Mod.	Z	De	Dp	H	F	d	D	V+H	L	Lm
2	16	34.8	32.0	23.5	8	25.3	8	33	—	13.6
	19	40.8	38.0	24.2	9	25.3	8	36	—	12
	22	46.8	44.0	27.9	10	30.3	10	42	—	14
	26	54.8	52.0	31.4	12	35.3	12	48	—	13.7
	30	62.8	60.0	34.1	13	40.3	12	54	—	17
2.5	16	43.5	40.0	28.1	10	30.3	12	40	—	15.2
	19	51	47.5	27.1	11	35.3	12	42	—	13
	22	58.5	55.0	30.1	12	45.3	12	48	—	15.7
	26	68.5	65.0	33.2	15	45.3	15	54	—	16
	30	78.5	75.0	39.0	16	50.3	15	64	—	20
3	16	52.2	48.0	31.7	12	40.3	12	46	—	18.1
	19	61.2	57.0	36.0	13	40.3	14	54	—	17.1
	22	70.2	66.0	36.9	15	50.3	15	58	—	17.1
	26	82.2	78.0	38.4	17	50.3	15	64	—	18
	30	94.2	90.0	43.8	19	60.3	20	74	—	22
3.5	16	60.9	56.0	36.4	14	45.3	15	53	—	19.8
	19	71.4	66.5	36.9	15	50.3	15	58	—	18
	22	81.9	77.0	39.1	17	55.3	15	64	—	18
	26	95.9	91.0	42.2	20	60.3	20	72	—	20
	30	110	105.0	47.3	23	70.3	20	82	43	22
4	16	69.7	64.0	44.3	15	50.3	15	64	—	25.1
	19	81.7	76.0	44.4	18	55.3	18	68	—	22
	22	93.7	88.0	45.9	20	60.3	18	74	—	22
	26	109.7	104.0	48.0	23	70.3	20	82	43	22
	30	125.7	120.0	54.2	26	80.3	25	94	49	25
4.5	16	78.4	72.0	46.3	17.5	55.3	18	68	—	25
	19	91.8	85.5	47.3	20	60.3	20	74	—	25
	22	105.3	99.0	50.1	22	70.3	20	82	—	25
	26	123.3	117.0	53.2	25	75.3	20	92	45	25
	30	141.4	135.0	60.0	29	80.3	25	105	54	28
5	16	87.1	80.0	48.9	18	60.3	20	74	—	25
	19	102.1	95.0	52.2	22	60.3	20	82	—	25
	22	117.1	110.0	58.2	24	80.3	20	94	52	30
	26	137.1	130.0	62.7	29	80.3	20	105	57	30
	30	157.1	150.0	68.9	32	80.3	30	119	63	35

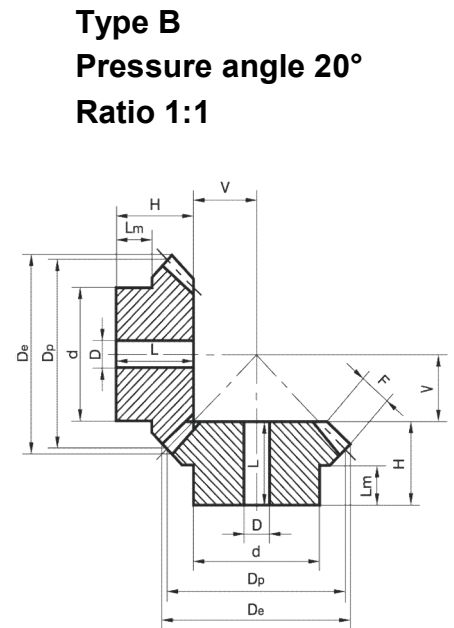

Mod.	Z	De	Dp	H	F	d	D	V+H	L	Lm
2	15	34.8	30.0	26.0	11.5	25.3	8	45	—	13.8
	30	61.2	60.0	29.8	11.5	40.3	12	39	27	18
2.5	15	43.5	37.5	31.8	15	32.3	12	55	—	16.2
	30	76.5	75.0	33.7	15	45.3	15	45	30	20
3	15	52.2	45.0	37.3	17	40.3	12	66	—	19.8
	30	91.8	90.0	42.1	17	55.3	15	56	38	25
3.5	15	60.9	52.5	46.1	20.5	45.3	15	79	—	24.7
	30	107.1	105.0	45.0	20.5	60.3	20	61	40	25
4	15	69.6	60.0	48.6	22.5	50.3	20	87	—	24.6
	30	122.3	120.0	57.3	22.5	80.3	20	76	52	25
4.5	15	78.3	67.5	51.4	26	60.3	20	94	—	24.7
	30	137.6	135.0	60.3	26	80.3	25	81	53	35
5	15	87.0	75.0	57.6	30	60.3	20	104	—	25.3
	30	152.9	150.0	62.5	30	80.3	25	85	56	35

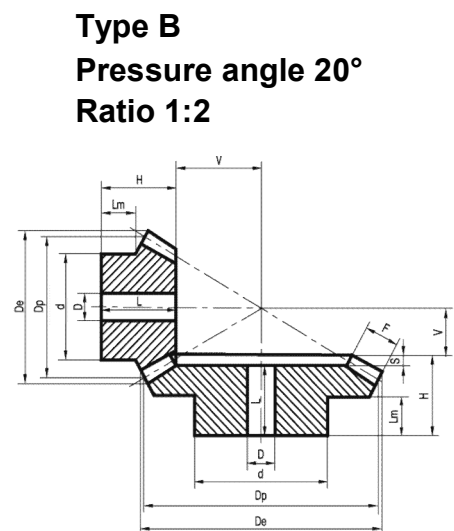

Accept custom made gears.

Mod.	Z	De	Dp	H	F	d	D	V+H	L	Lm
2	15	35.4	30	28.9	14	25.3	8	60	—	14.2
	45	90.8	90	32.1	14	45.3	15	42	29	20
2.5	15	44.2	37.5	34.6	18	32.3	12	73	—	15.9
	45	113.4	112.5	39.7	18	60.3	20	52	36	25
3	15	53	45	41.3	21	40.3	15	88	—	19.7
	45	136.1	135	47.2	21	60.3	20	62	42.5	30
3.5	15	61.9	52.5	49.6	23.5	45.3	15	105	—	25.1
	45	158.8	157.5	54.4	23.5	80.3	20	72	49	35
4	15	70.7	60	54.3	27.5	50.3	20	117	—	25.4
	45	181.5	180	57	27.5	80.3	22	77	51	35
4.5	15	79.5	67.5	55.2	28.5	55.3	20	128	—	24.8
	45	204.2	202.5	63.9	28.5	90.3	25	87	57	40
5	15	88.4	75	65.3	33	60.3	20	145	—	30
	45	226.9	225	66.7	33	90.3	28	92	59	40

**Type B**  
**Pressure angle 20°**  
**Ratio 1:3**

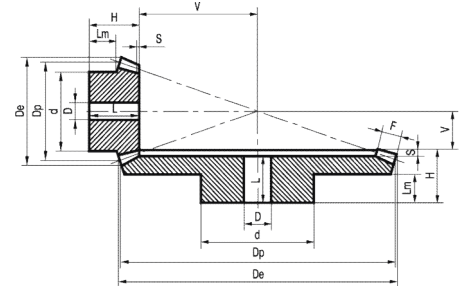

Mod.	Z	De	Dp	H	F	d	D	V+H	L	Lm
2	15	35.6	30	31	16	25.3	8	75	—	14.4
	60	120.6	120	37.6	16	60.3	16	48	34	25
2.5	15	44.5	37.5	38.1	19	32.3	14	94	—	18.4
	60	150.7	150	44.8	19	60.3	20	58	40	30
3	15	53.3	45	48.1	23	40.3	15	115	—	24.5
	60	180.8	180	53.2	23	80.3	20	69	48	35
3.5	15	62.2	52.5	52.1	26	45.3	15	131	—	25.1
	60	211	210	60.4	26	90.3	25	79	54	40
4	15	71.1	60	55.1	30	50.3	20	145	—	23.8
	60	241.1	240	60.8	30	90.3	28	82	53	40
4.5	15	79.9	67.5	59.1	34	60.3	20	160	—	24.1
	60	271.2	270	68.2	34	100.3	30	92	61	40
5	15	88.8	75	68.1	38	70.3	20	180	—	29.4
	60	301.3	300	73.5	38	110.3	30	100	66	40

**Type B**  
**Pressure angle 20°**  
**Ratio 1:4**

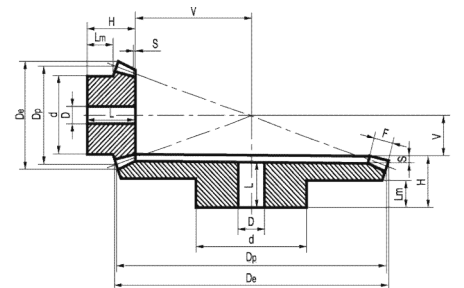

Material selection: Steel C45, 42CrMo, 20CrMnTi.  
 Surface treatment selection: Hardening teeth, Oil, Black oxide, Carburizing.  
 For large module gears, or not 45°gears, pls contact Fekerman directly.  
 Accept custom made gears.